

They should also keep in mind that the position of the camera head is not centered in the tip of the 6.5mm diameter flexible portion. This was missing from the presentation. You can see the offset in the screen-snip below ( where it is shown upside down) and the attached picture IMG\_6758, which also shows where the light is positioned (the yellow dot).

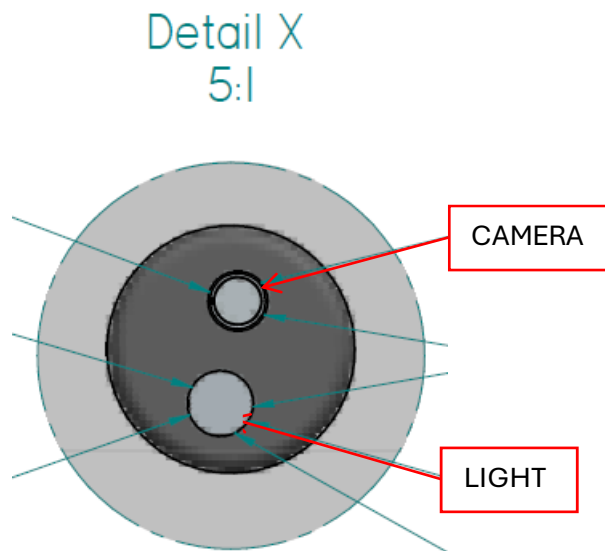

I would say that other important notes for the design to keep in mind would be:

- 1) Do not block the camera or light (some occlusion is okay, more so for the light than the camera, but the light is essential to see within the ear)
- 2) Orientation of the camera (the light is at the top of the image, the cable is at the bottom) – mainly to clock the position with how it is held by the user
- 3) How it will be held by the user (ex. IMG\_7287 and IMG\_7292 is how we held it for examining the mouth. Trying to hold it by the handle was unwieldy.)

- There is a machined and/or welded on bump where the flexible camera meets the metal barrel, which stands proud of the metal barrel diameter (see snip below). The presentation only mentions mocking up the two diameters to test on. If you do get an adaptor from these teams you want to use, you will have to make a cutout to slip over this section since it is not mentioned in the presentation dimensions or requirements.
  - o Also, this bump might be acting as a locator and/or the stud for snapping on the laryngoscope blade. Perhaps the groove behind it too.



o